



# SHURFLO PIRANHA™ BALLAST 800 GPH MARINE BALLAST PUMP – PRODUCT TECHNICAL DATA SHEET

OEM: 357-116-00  
AFTERMARKET: 357-116-10



**APPLICATION:**  
Ballast tanks fills

**PUMP DESIGN:**

Type: Centrifugal Pump  
Outlet Port: 3/4" Barb  
Inlet Port: 3/4" NPT-M  
Liquid: 130°F [54°C] Max  
Prime: Flooded Inlet  
Run Dry: No  
Inlet Pressure: 30 PSI Max. [2.06 Bar]

**ELECTRICAL:**

Motor: 12V DC Permanent Magnet, Continuous Duty  
Protection: Need External Fuse (not supplied)  
Leads: 6 feet [1.8M] Tinned 16 AWG  
Fuse: 6 Amp Recommended  
Control: No Control – External fuse required

**MATERIALS OF CONSTRUCTION:**

Housings: High Strength Nylon  
Impeller: High Strength Nylon  
Hardware: Stainless Steel

**AGENCY APPROVALS:**

Ignition Protection 8846, CE,

**SHIPPING INFORMATION:**

Approx. Net Weight: 1.4 Lbs. [0.63 Kg] each  
Carton Qty.: 24  
Approx. Carton Weight: 33 Lbs. [ 15 Kg]  
Approx. Carton Size: 24" L X 18" W X 11" H [61cm x 46cm x 28cm]



**RELATED DOCUMENTS:**

Catalog: MS-030-140  
 Application Spec Guide: MS-020-005  
 Installation Manual: 911-1034  
 Aftermarket Warranty: 911-1045

**TYPICAL PERFORMANCE AT 13.6V**

PRESSURE		FLOW		CURRENT
Meters	Ft	GPH	LPM	AMPS
0	0	800	3028	2.3
0.30	1	700	2649	2.8
0.60	2	600	2271	3.0
0.91	3	500	1892	3.4
1.21	4	400	1514	3.5
2.43	5	300	1135	3.6
4.24	14	0.0	0.0	2.98

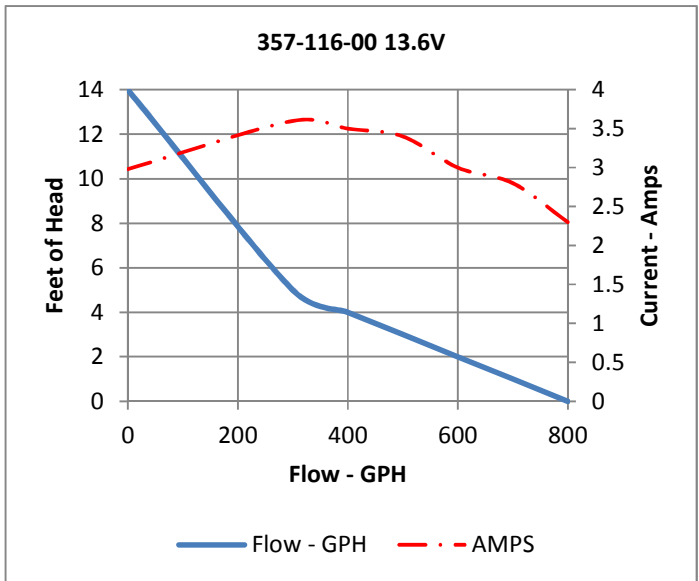

**DIMENSIONS**

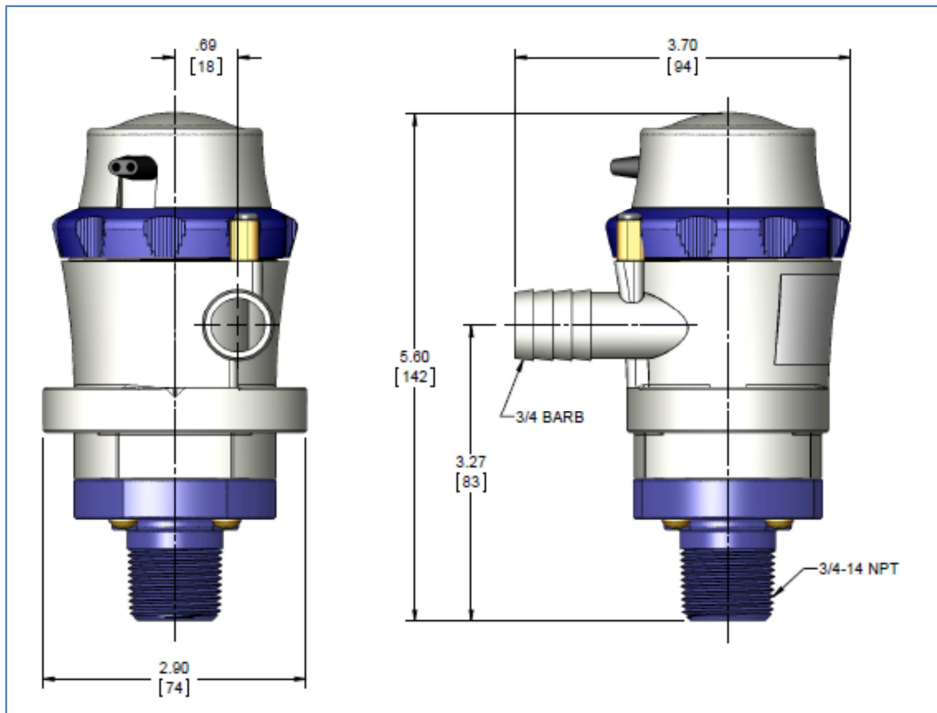

**WATER PURIFICATION**

3545 Harbor Gateway South, Suite 103, Costa Mesa, CA 92626, (800) 854-3218 www.SHURFLO.com

All Pentair trademarks and logos are owned by Pentair, Inc. All other brand or product names are trademarks or registered marks of their respective owners. Because we are continuously improving our products and services, Pentair reserves the right to change specifications without prior notice. Pentair is an equal opportunity employer.